

CRANE OMNIA 2TL

LIFTING CAPACITY 2000 KG

**MOTORISED COUNTERBALANCED CRANE WITH RIGID ARM AND TRIPLE TELESCOPIC BOOM
ELECTRIC LIFT/LOWER/EXTEND/RETRACT THROUGH CONTROL LEVERS AT ADJUSTABLE SPEED**



Modell		OMNIA 2TL
Drive		Electric
Rotation		Rigid arm
Arm lifting		Electric – control lever
Arm lowering		Electric – control lever
Arm extension		Electric – control lever
Width	mm/in.	1116 / 44
Max capacity with standard triple boom	Kg / lb	2000 / 4409 * see load chart below
Weight of the crane (counterweight incl.)	Kg / lb	1900 / 4188
Battery type standard		Maintenance free AGM
Batteries nos.	pcs	2
Battery voltage / nominal capacity	V / Ah	12 / 260
Lifting motor	W	3000
Traction motor	W	1200

CRANE OMNIA 2TL MAIN DIMENSIONS

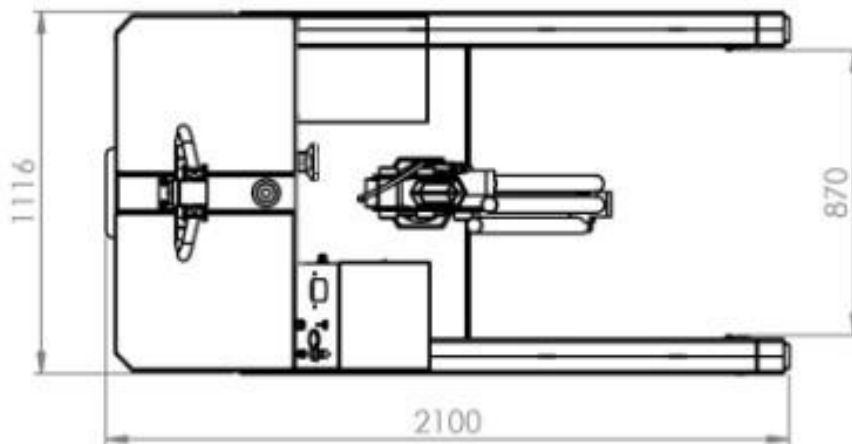
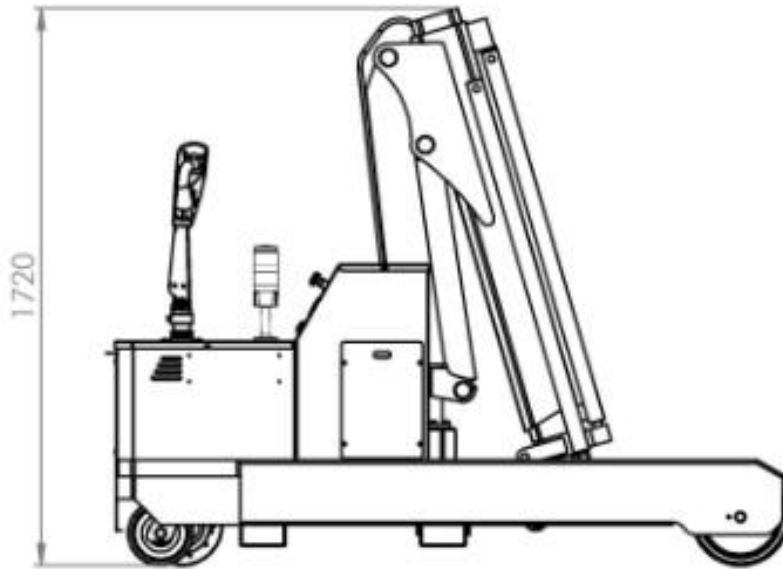

CRANE OMNIA 2TL DETAILED DIMENSIONS WITH STANDARD TELESCOPIC ELECTRIC TRIPLE BOOM

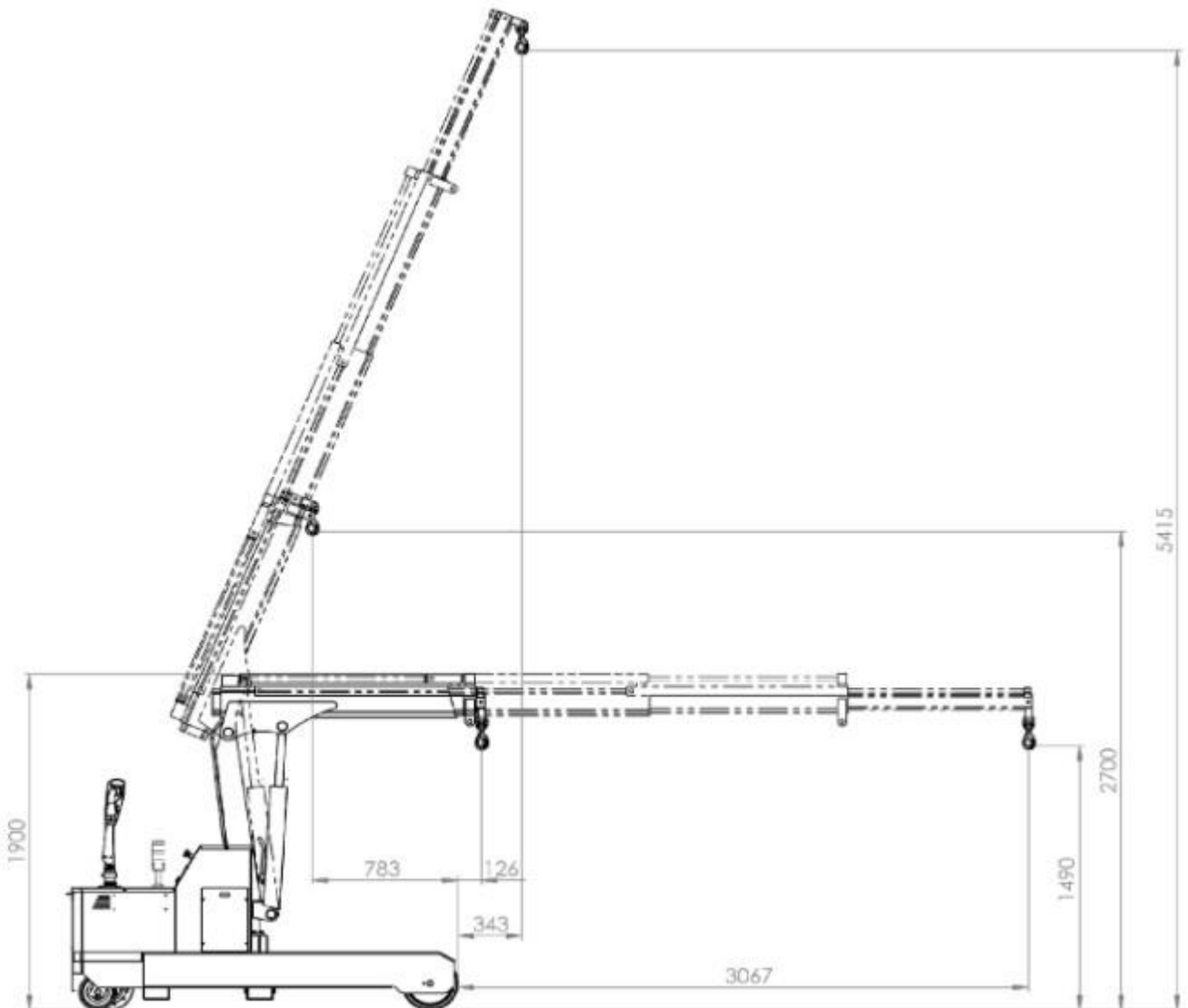

CRANE OMNIA 2TL LOAD CHART

