

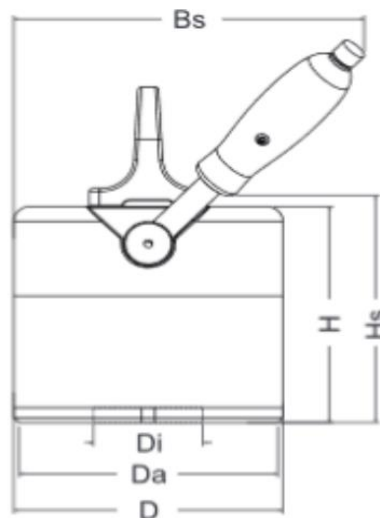

## FX-C SERIES MAGNETIC LIFTERS FOR RINGS AND FLANGE PLATES

FX-C lifting magnets have a round multi-pole anchorage surface, designed for lifting rings, bushings, bearing housings, flange plates and similar parts. The load specification is valid for the contact of the entire surface with pieces that overlap from the inside to the outside. Parts with a smaller contact surface can have a capacity of 3.5 kg max. per cm<sup>2</sup> of surface. Made in Germany. Standard conformity CE/EN 13155/MRL 2006/42 EWG.



MODEL	MAX CAPACITY from thickness ( mm )	CAPACITY ( kg )	CAPACITY per cm <sup>2</sup> ( kg )	DIMENSIONS ( mm )					WEIGHT kg
				D	Da.Di	H	Hs	Bs	
FX – C175	10	175	3,5	120	114-40	130	138	185	7,5
FX – C250	12	250	3,5	160	152-65	145	153	210	15
FX – C450	15	450	3,5	250	240-100	155	168	275	35
Safety Factor 3.5 – Test Method EN 13155 – Max. operation temperature 80°C									

[www.flexlifting.com](http://www.flexlifting.com)

Flex Lifting - a brand of AxA Group srl  
Via Morandi 21, 40060 Toscanella di Dozza (Bologna) Italy Tel +39 0542673434 email: [info@flexlifting.com](mailto:info@flexlifting.com)